

MODULAR SPORTS SOLUTION SPECIFICATION
PREPARED FOR

Penn Park Mini-Pitch

Madison, WI
January 27, 2023

Project # 223637

SUBMITTED BY:

Musco Sports Lighting, LLC

100 1st Ave W
P.O. Box 808
Oskaloosa, IA 52577, USA
Phone: +1-641-673-0411
Toll Free: +1-800-825-6020
Fax: +1-641-673-4852



Modular Sports Solution

PART 1 – GENERAL

1.1 SUMMARY

- A. Work covered by this section of the specifications shall conform to the contract documents, engineering plans as well as state and local codes.
- B. The purpose of these specifications is to define the modular sports solution design standards for Penn Park Mini-Pitch. The manufacturer / contractor shall supply equipment to meet or exceed the standards set forth in these specifications.
- C. Modular sports solutions will be provided for the following venues:
 - 1. Penn Park
- D. The primary goals of this project are:
 - 1. Modular Sports Solution: Fully contained modular sports solution shall include: fence panels and goals, ADA-compliant entryways, seating accommodations.
 - 2. Cost of Ownership: In order to reduce the operating budget maintenance costs of modular sports structure shall be eliminated for the duration of the warranty period as defined in the warranty agreement.

PART 2 – PRODUCT

2.1 MODULAR SPORTS SOLUTION CONSTRUCTION

- A. Manufacturing Requirements: All components shall be designed and manufactured as a system.
- B. Durability: All exposed components shall be constructed of corrosion resistant material and/or coated to help prevent corrosion. All exposed carbon steel shall be hot-dip galvanized per ASTM A123. All exposed aluminum shall be powder coated with high performance polyester or anodized. All exterior reflective inserts shall be anodized, coated, and protected from direct environmental exposure to prevent reflective degradation or corrosion. All exposed hardware and fasteners shall be stainless steel, passivated and coated with aluminum-based thermosetting epoxy resin for protection against corrosion and stress corrosion cracking. Structural fasteners may be carbon steel and galvanized meeting ASTM A153 and ISO/EN 1461 (for hot-dip galvanizing), or ASTM B695 (for mechanical galvanizing). All wiring shall be enclosed.
- C. System Description: Modular sports solution shall consist of the following:
 - 1. Pitch fence panels and goal assembly construction
 - a. Mini-pitch size:
 - (1) - 104 ft (32 m) x 50 ft (15 m)
 - b. Assemblies: Fence panels, and goal assemblies shall be prefabricated for ease of assembly. Component assemblies will bolt together to form the final construction. No single panel or component shall weigh more than 2000 lb (907 kg) for ease of installation with forklift or telehandler.
 - c. Fence panels: Sideline fence panels shall have a finished height of at least 3 ft (0.91 m). End line fence panels shall have a finished height of at least 6 ft (1.82 m). All panels shall be constructed of 2 in (50 mm) round or square tube steel and 0.120 in (3 mm) thick steel plate.
 - d. Goals: Shall have minimum size 90 in (2.3 m) wide x 70 in (1.7 m) tall x 34 in (0.9 m) deep and be constructed of 2 in (50 mm) round or square tubing, 0.120 in (3 mm) thick steel plate, and 0.19 in (4 mm) chain link.
 - e. Gated Entryways:
 - 1) Are required to be ADA compliant

- 2) Must provide at least 2 points of entry/egress (one on each side of the pitch)
- 3) Must provide latchable gates
- f. Anchor plates: Each fence panel and component shall have anchor plates for securing the system to the ground. Each anchor plate shall be equipped with leveling hardware for independent alignment of each component.
- 2. Steel seating accommodations
 - a. Modular sports solution will be equipped with seating accommodations.
 - 1) Bench style seating accommodations for up to 20 people
 - 2) Cupholders equivalent to seating accommodations
- 3. Storage:
 - a. Lockable storage units shall be integrated into the modular structure.

2.2 STRUCTURAL PARAMETERS

- A. Wind Loads: Wind loads shall be based on the 2015 International Building Code. Wind loads to be calculated using ASCE 7-10, an ultimate design wind speed of 115mph and exposure category C.
- B. Foundation Design: Foundation design shall be sufficient to withstand forces from all attached equipment (including signage) and be evaluated by a structural engineer.

PART 3 – EXECUTION

3.1 DELIVERY TIMING

- A. Delivery Timing Equipment On-Site: The equipment must be on-site 8-10 weeks from receipt of approved submittals and receipt of complete order information.

3.2 FIELD QUALITY CONTROL

- A. Upon substantial completion of the project and in the presence of the Contractor, Project Engineer, Owner's Representative, and Manufacturer's Representative, a final inspection shall be completed.
- B. The contractor/manufacturer will be held responsible for any and all changes needed to bring these fields into compliance with the specification. Contractor/Manufacturer will be held responsible for any damage to the fields during these repairs.

3.3 WARRANTY AND GUARANTEE

- A. 10-Year Warranty: Each manufacturer shall supply a signed warranty covering the entire system for 10 years from the date of shipment. Manufacturer shall maintain specifically funded financial reserve to assure fulfillment of the warranty for the full term. Warranty does not cover weather conditions events such as lightning or hail damage, improper installation, vandalism or abuse, unauthorized repairs or alterations, or product made by other manufacturers.
- B. Maintenance: Manufacturer is responsible for removal and replacement of failed components, including all parts, labor, shipping, and equipment rental associated with maintenance.

PART 4 – DESIGN APPROVAL

4.1 PRE-BID SUBMITTAL REQUIREMENTS (Non-Musco)

- A. Design Approval: The Owner / engineer will review pre-bid submittals per section 4.1.B from all the manufacturers to ensure compliance to the specification 10 days prior to bid. If the design meets the design requirements of the specifications, a letter and/or addendum will be issued to the manufacturer indicating approval for the specific design submitted.

- B. Approved Product: Musco's Mini-Pitch System™ Modular Sports Solution is the approved product. All substitutions must provide a complete submittal package for approval as outlined in Submittal Information at the end of this section at least 10 days prior to bid. Special manufacturing to meet the standards of this specification may be required. An addendum will be issued prior to bid listing any other approved manufacturers and designs.
- C. All listed manufacturers not pre-approved shall submit the information at the end of this section at least 10 days prior to bid. An addendum will be issued prior to bid; listing approved manufacturers and the design method to be used.
- D. Bidders are required to bid only products that have been approved by this specification or addendum by the Owner or Owner's Representative. Bids received that do not utilize an approved system/design, will be rejected.

REQUIRED SUBMITTAL INFORMATION FOR ALL MANUFACTURERS (NOT PRE-APPROVED) 10 DAYS PRIOR TO BID

*All items listed below are mandatory, shall comply with the specification and be submitted according to pre-bid submittal requirements. Complete the Yes/No column to indicate compliance (Y) or noncompliance (N) for each item. **Submit checklist below with submittal.***

Yes/No	Tab	Item	Description
	A	Letter/ Checklist	Listing of all information being submitted must be included on the table of contents. List the name of the manufacturer's local representative and his/her phone number. Signed submittal checklist to be included.
	B	Equipment Layout	Drawing(s) showing field layouts
	C	Performance Guarantee	Provide performance guarantee including a written commitment to undertake all corrections required to meet the performance requirements noted in these specifications at no expense to the owner.
	E	Warranty	Provide written warranty information including all terms and conditions. Provide ten (10) references of customers currently under specified warranty in the state of Wisconsin.
	F	Project References	Manufacturer to provide a list of projects where the technology proposed for this project has been installed in the state of Wisconsin. Reference list will include project name, project city, installation date, and if requested, contact name and contact phone number.
	G	Product Information	Complete bill of material and current brochures/cut sheets for all product being provided.
	H	Delivery	Manufacturer shall supply an expected delivery timeframe from receipt of approved submittals and complete order information.
	I	Non-Compliance	Manufacturer shall list all items that do not comply with the specifications. If in full compliance, tab may be omitted.

The information supplied herein shall be used for the purpose of complying with the specifications for Penn Park Mini-Pitch. By signing below I agree that all requirements of the specifications have been met and that the manufacturer will be responsible for any future costs incurred to bring their equipment into compliance for all items not meeting specifications and not listed in the Non-Compliance section.

Manufacturer: _____

Signature: _____

Contact Name: _____

Date: ____/____/____

Contractor: _____

Signature: _____

GENERAL NOTES:

- 1) MINI PITCH TO BE INSTALLED WITHOUT LIGHTING POLE LUMINAIRES, ECES.
- 2) NO ELECTRICAL REQUIRED.
- 3) REQUIRES GROUND ROD INSTALLATION.
- 4) FUTURE POLE PLUG IS INSTALLED IN PLACE OF POLE.

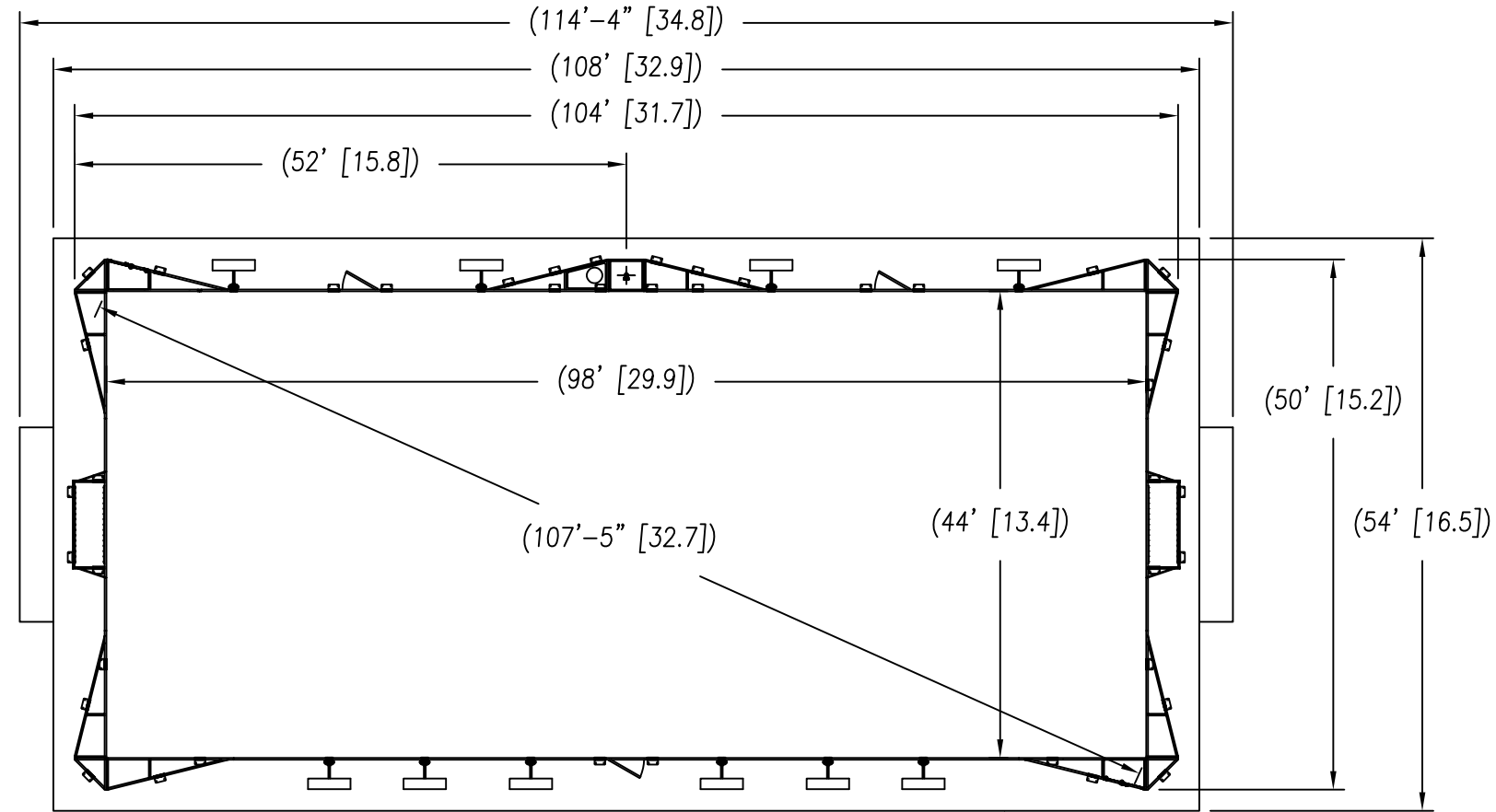

NOTES:

1. SPECIFICATIONS FOR ALL HARDWARE CONNECTING FRAMES.
 SIZE: 1/2-13
 MATERIAL: GRADE 1 STEEL OR BETTER.
 FINISH: HOT DIP GALVANIZED C CLASS
2. GROUND ANCHOR SPECIFICATIONS. 122 ANCHORS ARE USED FOR THIS FIELD SIZE.
ASPHALT SURFACE:
 TYPICAL PULL RESISTANCE: 2,500 LBS
 TYPICAL SHEAR RESISTANCE: 2,500 LBS
3. WIND LOADING LIMITS:
BANNERS MOUNTED ON ALL SURFACES
 IBC 2015 115 MPH EXPOSURE C

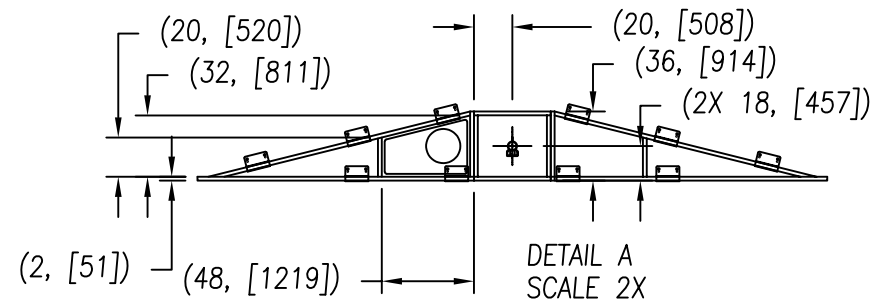

DETAIL A
SCALE 2X

MINIMUM PAD

ELECTRICAL NOTES: FUTURE POLE PLUG IN PLACE OF POLE

PROJECT VOLTAGE: NA

CONTROL VOLTAGE: NA

SURFACE TYPE: ASPHALT

MINIMUM PAD SURFACE: 108' X 54'
32.9M X 16.5M

DWG REF: SBS-300

Penn Park Mini-Pitch
Madison, WI, USA
MINI PITCH, 104' X 50' (31.7 X 15.2) [B]

CORPORATE OFFICE:
P.O. Box 808
100 1st Avenue West
Oskaloosa, Iowa 52577
+1-800-823-8020
+1-641-673-0411

REVISIONS:	DATE:	BY:	I.R.L.

JOB NUMBER:	223637
DRAWN BY:	JFM
CHECK BY:	
REPRESENTATIVE:	
SCALE:	1/200
DATE:	27JAN23
DRAWING NUMBER:	223637X3
	1 OF 1 SHEETS

ENGINEERING REFERENCE DOCUMENT
DO NOT USE TO MANUFACTURE PRODUCT
ENG_REF_DOC_A

Information contained herein is the confidential property of Musco Sports Lighting, LLC and/or its parent companies, affiliates, successors and assigns. Reproduction, distribution, or use of the information other than its limited, intended purpose without express written permission is prohibited.

